

INDUSTRIAL VEHICLES INTERNATIONAL, INC.

EnviroVibe

An Acoustically Efficient 10 to 300 hz. Vibrator

minibuggy

An Environmental Low Impact Vehicle System

The **EnviroVibe** is a low impact vibrator system designed for Oil and Gas reflection surveys. The system is optimized for operation in environmentally restricted or populated areas. The **EnviroVibe** provides improved low frequency output and 3,000 pounds additional force output when compared to the 'minivib' II. The advanced system features include high fidelity and broad band width, low source generated ground pressure, low vehicle generated ground pressure, sound limiting systems, and ergonomic operator features. Wagon wheel articulated steering, which was first introduced to the geophysical industry by IVI in 1984, offers safe and reliable off road operation. This system is an excellent choice for environmentally sensitive, high resolution surveys.



Side View Dimensional Drawing of the **EnviroVibe** mounted on the 'minibuggy'

meters

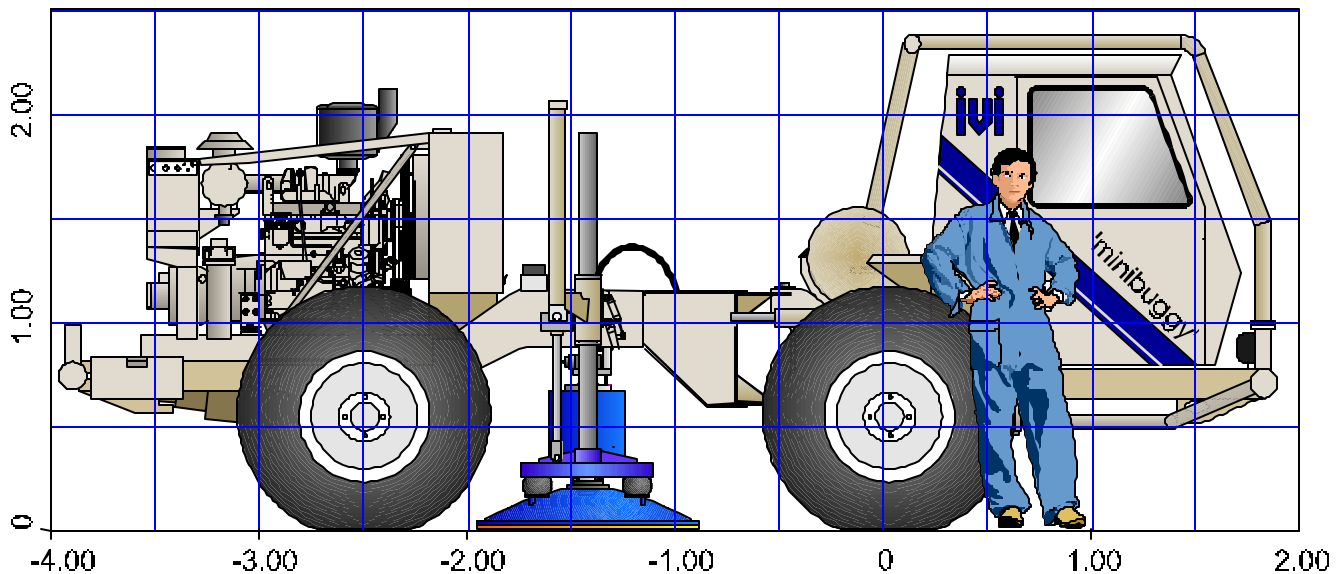

EnviroVibe

VISIT THE IVI WEBSITE AT <http://www.indvehicles.com>

'minibuggy' Vehicle

CATEGORY	ENGLISH	METRIC
Total Weight	17,000 Pounds	8.397 kgf.,
Front Axle Weight	7,900 Pounds	3.902 kgf.
Rear Axle Weight	9,100 Pounds	4.495 kgf.
Traction System Pressure	3,500 PSI	207 bar
Transmission	Hydrostatic 3 Speed	Hydrostatic 3 Speed
Cab	2 Man Vista Cab	2 Man Vista Cab
Turning Radius	169 Inches	4,29 meters
Diesel Engine - John Deere	113 Horsepower @ 2500 RPM	84 kW @ 2500 RPM
Axles	Inboard Planetary	Inboard Planetary
Brakes	Enclosed Wet Disc	Enclosed Wet Disc

EnviroVibe

CATEGORY	ENGLISH	METRIC
Max Theoretical Peak Force	15,000 Pounds	66.000 N.
Mass Piston Area	5.00 Inches ²	32,2 cm ²
Reaction Mass Weight	1,750 Pounds	794 kgf.
Reaction Mass Stroke	2.75 Inches	6,99 cm.
Servo Valve	60 GPM	227 l/m
Servo Valve Pilot Filter	3 Micron	3 Micron
Baseplate Area	1,810 Inches ²	11.675 cm ²
Baseplate Assembly Weight	855 Pounds (with pad)	388 kgf. (with pad)
Lift System Stroke	38 Inches	96,5 cm.
Lift Cylinder Diameter	2.5 Inches	6,3 cm.
Lift Synchronization	Mechanical Crossbeam	Mechanical Crossbeam
Vibrator Pump Flow	50 GPM	189 l/m
Holddown Weight	15,000 Pounds	7.409 kgf.

OPTIONS

OPTION	DESCRIPTION
Front Winch	Hydraulically powered 8,000 pound winch
Noise Reduction Panels	Reduces the ambient noise of the 'minibuggy' from 82 dba to 79 dba, 7 meters from the side of the vehicle at full engine RPM
Cold Weather Options	Various heaters, covers, and other equipment for cold temperatures
Optional Lighting	Various vehicle lighting configurations for different local requirements
Cab Protective Structure	A cab structure designed to protect the cab in rugged conditions
Flotation Tire	Super Terra Grip 48x31-20 --10 psi ground pressure with no penetration

Specifications are subject to change without notice. All specifications reflect standard equipment.

EnviroVibe



INDUSTRIAL VEHICLES INTERNATIONAL, INC.

6737 EAST 12TH STREET, TULSA, OKLAHOMA 74112 U.S.A. PHONE (918) 836-6516 FAX (918) 838-9529
E-MAIL ivi@indvehicles.com